

NM0019-c

Assembly instructions EOLIS bridge

Reference : 1500.11

Necessary tools :

- 1x Drill
- 1x bit $\varnothing 6.5$
- 1x Allen key 5mm
- 1x Allen key 10mm



Step 1 : (if the ABS is already drilled, go directly to the step 2)

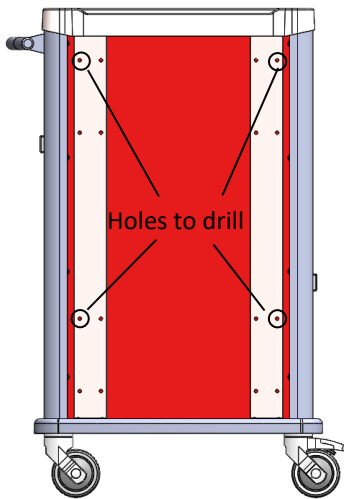

Trolley 12 Levels (1005.03)

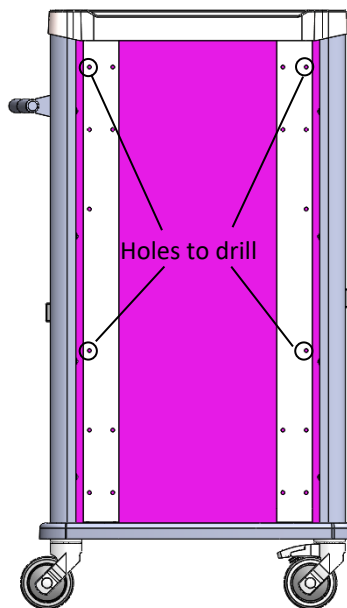

Trolley 14 Levels (1005.02)

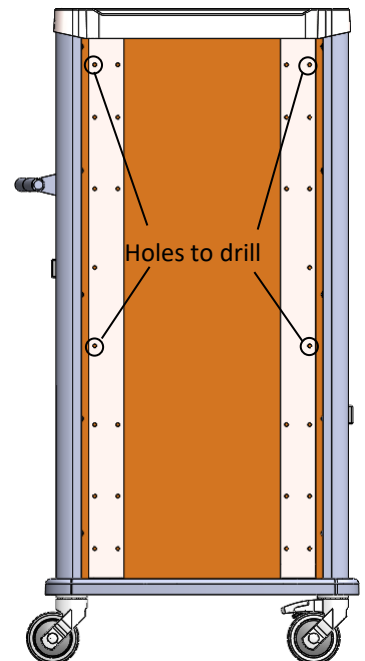

Trolley 16 Levels (1005.01)

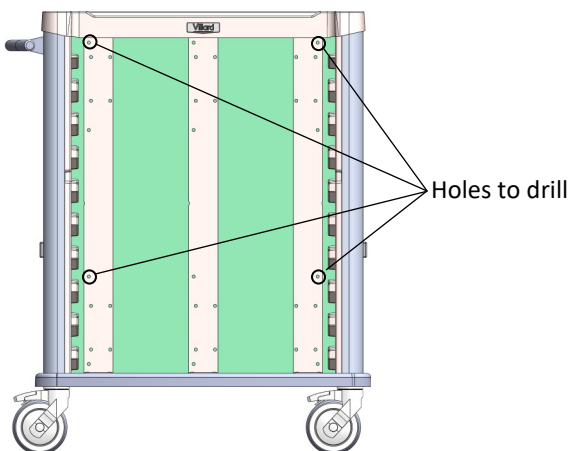

Trolley 10 levels (1006.01)

Trolley 9 levels (1006.11)

Compact trolley 10 levels (1005.11)

Drill the back of the trolley through the holes on the reinforcement with the help of a bit $\varnothing 6.5$ mm.

Warning !

The position of the holes to drill are different depending on the height of the trolley

NM0019-c

Assembly instructions EOLIS bridge

Reference : 1500.11

Step 2 :

- Install the bridge with the screws M6x25, the washers Ø6 (picture 1) and the nut, don't forget to place the plastic spacer ring between the bridge and the back of the trolley (Picture 2).

